

Product Details

41HG0100

E.G. 1" Split Ring Extension Hanger (Hinged)

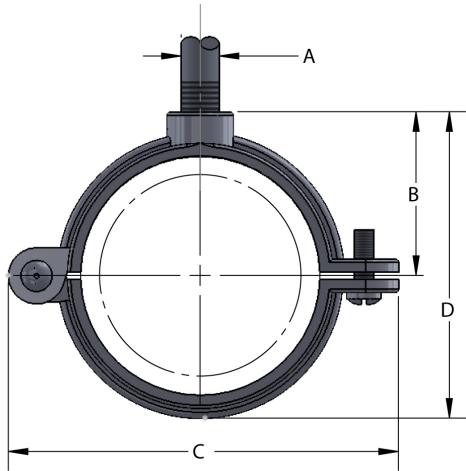

Image for illustrative purposes only.
May not reflect actual part number

Figure	41H - Hinged Split Ring
Finish/Material Code	G
Material	Malleable Iron
Finish	Electro-Galvanized
Size Code	0100
Size Type Code	Iron Pipe Size (IPS)
IP Size	1
Size (mm)	25.4
Pipe OD (in)	1.315
A (in.)	3/8-16
B (in.)	1 1/8
C (in.)	2 3/4
D (in.)	2
Weight Each (lbs.)	0.147
Max Rec Load (lbs.)	180
MSS Type	#12
D/I	Imported
List Price	
Box Quantity	100

Prices and Specifications subject to change without notice. While the information in this catalog has undergone rigorous, prepublication verification process, Empire Industries, INC. is not responsible for any inaccuracies due to undetected error.

Domestically Manufactured*:

This product's main components are manufactured in the U.S. (fasteners may be of foreign origin)

Domestically Manufactured:**

This product is wholly manufactured in the U.S.

Import:

This product's country of origin is other than the U.S.